

# Noninvasive Cardiac Output Estimation Using a Novel Photoplethysmogram Index

L. Wang, Emma Pickwell-MacPherson, Y. P. Liang and Y. T. Zhang

**Abstract**—Cardiac output (CO) monitoring is essential for indicating the perfusion status of the human cardiovascular system under different physiological conditions. However, it is currently limited to hospital use due to the need for either skilled operators or big, expensive measurement devices. Therefore, in this paper we devise a new CO indicator which can easily be incorporated into existing wearable devices. To this end, we propose an index, the inflection and harmonic area ratio (IHAR), from standard photoplethysmographic (PPG) signals, which can be used to continuously monitor CO. We evaluate the success of our index by testing on sixteen normotensive subjects before and after bicycle exercise. The results showed a strong intra-subject correlation between IHAR and  $CO_{imp}$  measured by the bio-impedance method in fifteen subjects (mean  $r = 0.82$ ,  $p < 0.01$ ). After least squares linear regression, the precision between  $CO_{imp}$  and CO estimated from IHAR ( $CO_{IHAR}$ ) was 1.40 L/min. The total percentage error of the results was 16.2%, which was well below the clinical acceptance limit of 30%. The results suggest that IHAR is a promising indicator for wearable and noninvasive CO monitoring.

## I. INTRODUCTION

IT is well known that heart rate, blood pressure and cardiac output (CO) are all essential physiological parameters of the human cardiovascular system. CO, defined as the blood volume ejected by the heart per minute (unit: L/min, where “L” means liter), is regarded as the ultimate expression of cardiovascular performance, since it indicates how well the heart is able to provide enough nutrition and oxygen to the peripheral organs and tissues. For human beings, in order to maintain a normal state of tissue perfusion and oxygen delivery condition, the baseline CO should be in the range of 4 L/min to 8 L/min. If CO gets out of this range, it is often a sign of cardiovascular disease, such as hypertension, stroke or heart failure. Hence, continuous CO monitoring plays an essential role in the evaluation, treatment, and follow-up of critically ill patients.

Ideally, a technology which measures CO should be

noninvasive, accurate, reliable and continuous. At present, no single method meets all these criteria. Intermittent thermodilution is widely accepted as the clinical golden standard. This method requires the insertion of a pulmonary artery catheter (PAC) to obtain one measurement per 3-4 minutes [1]. It is too invasive and non-continuous. Two existing less invasive and continuous methods are oesophageal Doppler monitoring and  $CO_2$  re-breathing, but both of these require skilled operators and expensive measurement devices [1]. Amongst the currently used methods, impedance cardiography is probably the only noninvasive and automatic technique. However, the impedance device is big and expensive, and its accuracy is often influenced by the change of electrode positions and the sweat on the skin [2]. Due to the disadvantages mentioned above, these methods are all unquestionably limited to bedside use. They are not portable, or wearable, so they are difficult to incorporate into home health care monitoring systems. To solve this problem, one of the best ways is to derive a new CO indicator from signals provided by the existing wearable device. Some preliminary studies have implied that the PPG signal could be a candidate for this application [3]-[6].

The PPG signal, which indicates the blood volume changes on site, is an optical signal that could be non-invasively obtained from body peripheral terminals, such as ear, finger and toe. The PPG acquisition components, including a pair of LED emitter and receiver, and related simple circuits, are cheap and small in size, and could be easily embedded into many existing wearable devices.

Although PPG is obtained peripherally, many previous studies have revealed that the PPG wave contour is primarily influenced by characteristics of the systemic circulation, but not the local perfusion [3]-[6]. Henry Lax and his colleagues [3] noted that when individuals had cold fingers, this “reduces the over-all amplitude but does not affect the configuration of the pulse wave”. Chowienczyk PJ found in his experiment that the vasodilation drugs which increased the local circulation in the upper arm could not change the corresponding finger PPG wave contour, while, the systematic insertion of vasodilation drugs, such as GTN, could change it substantially [4]. More recently, we have successfully utilized a parameter derived from the PPG wave to trace the change of total peripheral resistance (TPR) after bicycle exercise [5]. McCombie proposed a blind system identification method to calculate the cardiac output waveform from two PPG signals measured from different body locations, but only a qualitative aortic flow curve was

---

Manuscript received April 7, 2009. This work was supported in part by the Hong Kong Innovation and Technology Fund (ITF). The authors are grateful to Standard Telecommunication Ltd., Jetfly Technology Ltd., Golden Meditech Company Ltd., Bird International Ltd. and Bright Steps Corporation of their supports to the ITF projects.

Y. T. Zhang (phone: 852-2609-8459; e-mail: ytzhang@ee.cuhk.edu.hk), Emma Pickwell-MacPherson, Y. P. Liang and L. Wang are with the Joint Research Centre for Biomedical Engineering, Department of Electronic Engineering, The Chinese University of Hong Kong, Hong Kong SAR.

Y. T. Zhang is also with the Institute of Biomedical and Health Engineering, Shenzhen Institute of Advanced Technology, Chinese Academy of Sciences, China, and Key Laboratory for Biomedical Informatics and Health Engineering, Chinese Academy of Sciences, China.

obtained [6].

In this paper, we propose a novel indicator of CO, the inflection and harmonic area ratio (IHAR), which is derived from PPG signals. The ability of IHAR to trace CO changes was evaluated in a bicycle exercise experiment.

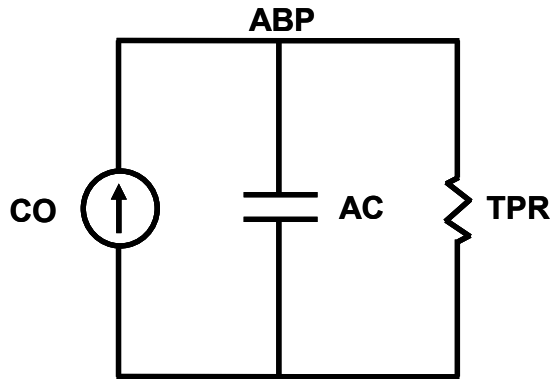

Fig. 1. Two-element Windkessel model.

## II. METHODOLOGY

According to the two-element Windkessel model shown in Fig. 1, CO could be calculated from the analysis of continuous arterial blood pressure waveform by a so called pulse contour method. In this model, the cardiovascular system is analogous to a current source connected with a two-element circuit. CO, which is mimicked by the mean amount of current passing through the TPR (total peripheral resistance), equals the mean pressure (mean arterial blood pressure, MBP) divided by the TPR:

$$CO = MBP/TPR \quad (1)$$

In this method, if a continuous arterial pressure waveform is obtained, MBP could be calculated beat to beat. TPR is firstly initialized by a pair of calibration CO and MBP data, and its value of the current beat is calculated from MBP and estimated CO of the previous beat, iteratively. The main shortcoming of such technique is that it needs either an

invasive arterial catheter or a bedside Finapres device for acquiring the continuous blood pressure measurement.

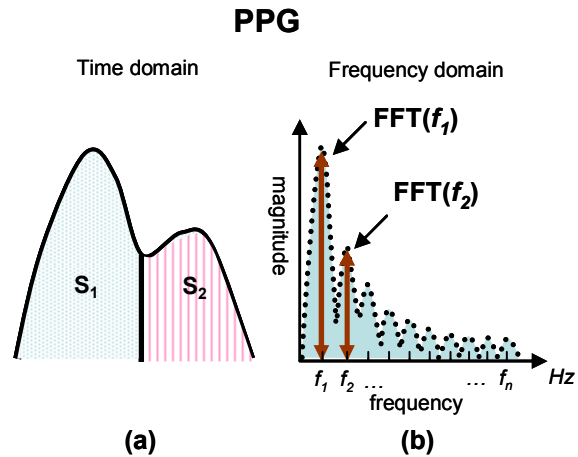

Fig. 2. (a) is PPG wave in the time domain. S1 and S2 are the areas under the whole PPG wave and the part of wave after the point of inflection, respectively.  $IPA=S2/S1$ . (b) is PPG wave in the frequency domain.  $FFT(f_n)$  is the magnitude at the nth harmonic.  $NHA =$

$$\frac{\sum_{n=2}^N FFT^2(f_n)}{\sum_{n=1}^N FFT^2(f_n)}$$

However, as shown in equation (1), blood pressure measurement is not a necessity for obtaining CO, if proper surrogates of MBP and TPR can be derived from other signals. According to wave reflection theory, arterial blood pulse could be divided into two waves: a first wave produced by heart pumping and a second wave produced by pulse wave reflection. Therefore, the inflection point area ratio (IPA), the area ratio of the second and first peak in the PPG wave (see Fig. 2 (a)), is mainly influenced by the strength of pulse wave reflection. Pulse wave reflection results from the impedance mismatch between different parts in the arterial system, e.g., the compliance and resistance mismatches between the big, elastic arteries and the small arteries. Studies have shown that approximate 90% of the TPR is located in the small arteries. Hence, if the small arteries contract, the TPR will change, which will change the

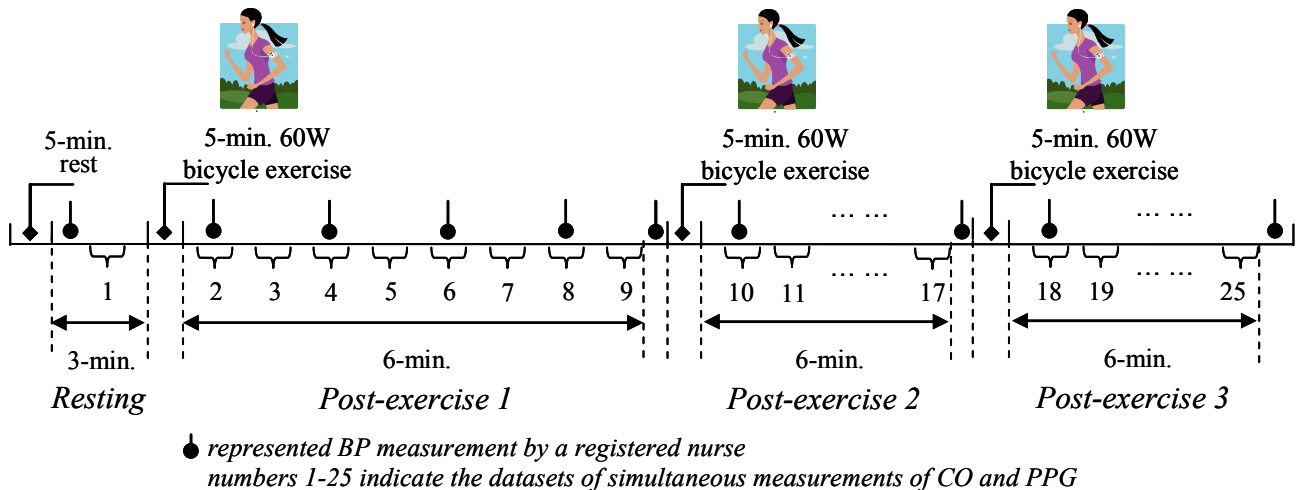

Fig. 3. Experiment procedure.

impedance mismatch, influence the strength of the wave reflection, and further change IPA. In our previous investigation [5], IPA has shown to be a very good indicator of TPR when it changes after exercise. The pulse wave reflection not only changes the shape of the PPG signal in the time domain, but also in the frequency domain. Our previous study [7] has proved that the normalized harmonic area (NHA), a parameter derived from frequency domain analysis (see Fig. 2 (b)), is related to pulse wave reflection and is strongly correlated with systolic and diastolic blood pressure. Therefore, IHAR, defined as NHA divided by IPA, is proposed as a potential CO indicator and expressed as follows:

$$IHAR = \frac{\left(1 - \frac{\sum_{n=2}^N FFT^2(f_n)}{\sum_{n=1}^N FFT^2(f_n)}\right)}{\left(\frac{S_2}{S_1}\right)} \quad (2),$$

where  $S_1$  and  $S_2$  are the areas under the whole PPG wave and the part of wave after the point of inflection in the time domain, respectively (see Fig. 2(a)), and  $FFT^2(f_n)$  is the square of the magnitude at the  $n^{\text{th}}$  harmonic of the PPG wave in the frequency domain (see Fig. 2(b)).

The performance of IHAR for CO estimation was evaluated in a bicycle exercise experiment. An impedance cardiograph device, Physio Flow PF-05 (Manatec Biomedical, Macheren, France), was used as the benchmark of CO measurement. The validity of this device has been established in both normotensive adults and cardiovascular patients versus the direct Fick method (lab golden standard of CO measurement) both at rest and exercise conditions [2] [8].

### III. EXPERIMENT PROTOCOL

16 normotensive volunteers (8 males and 8 females), aged from 22 to 34 years, participated in this study. Informed consent was obtained from each participant. The experimental procedures are depicted in Fig. 3. Upon arrival, subjects were asked to rest for 5 minutes. Then, the systolic blood pressure (SBP) and diastolic blood pressure (DBP) were measured from the left arm by a registered nurse. After this, PPG and cardiac output were recorded simultaneously for 1 min. Then, the subjects were asked to ride the bicycle (Corival V2, Lode VB, Groningen, Netherland) for 5 minutes at 60 W. Immediately after exercise, 6-min of PPG and CO data were continuously acquired, meanwhile, at time points after exercise of 0 min, 1.5 min, 3 min, 4.5 min and 6 min, blood pressure (BP) was measured. Then, the same 5 min exercise and post-exercise data acquisition procedures were repeated twice. PPG was recorded on the right index finger by an in-house designed acquisition system. CO was measured by the Physio Flow PF-05 impedance cardiograph device.

### IV. DATA ANALYSIS

For each subject, 25 datasets were obtained, including 1 dataset at rest and 8 datasets in each post exercise phase (see Fig. 3). The 8 datasets after each exercise were obtained from the 6-min continuous data divided by the intermittent BP measurements. As shown in Fig. 3, BP was also measured by a nurse every other dataset, e.g., during datasets 2, 4, 6, 8 for post exercise phase 1.

For offline analysis, each dataset of PPG signals was re-sampled to 100 Hz and divided into beat-to-beat waves. The start point of each beat is defined as the beginning of its systolic rise, which is also the end of the diastolic fall wave of the previous beat. Single PPG wave was transferred to the frequency domain by 512 points FFT (ensuring a resolution of more than 10 points per Hz). Then, beat-to-beat IHAR was calculated using equation (2). Meanwhile,  $CO_{\text{imp}}$  was obtained by the impedance cardiograph device, beat by beat. ‘‘Beat by beat’’ here meant that  $CO_{\text{imp}}$  was acquired and saved in a ‘‘beat to beat’’ format, but was actually calculated from the rolling average of eight impedance wave and five ECG wave in the algorithm. As a result, it was impossible in this study to compare IHAR with  $CO_{\text{imp}}$  in a beat-to-beat way, but only to compare the means of each dataset. For CO estimation, all datasets of IHAR and  $CO_{\text{imp}}$  were firstly used to produce  $CO = \alpha \cdot IHAR + \beta$  by the least squares linear regression method, and then, the  $CO_{\text{IHAR}}$  results were obtained from IHAR by the above equation.

### V. RESULTS

As shown in Table I, the hemodynamic parameters, including heart rate, systolic blood pressure, diastolic blood pressure and cardiac output, have significantly changed after each 5 min of bicycle exercise, compared with those obtained at rest ( $p < 0.05$ ).

The intra-subject correlation coefficients ( $r$ ) between IHAR and  $CO_{\text{imp}}$  are listed in Table II. For all subjects, IHAR was positively correlated to  $CO_{\text{imp}}$ . Except for subject 13 ( $p = 0.054$ ), there was a strong correlation between IHAR and  $CO_{\text{imp}}$  in the other 15 subjects (mean  $r = 0.82$ ,  $p < 0.01$ ).

TABLE I  
CHANGES OF HEMODYNAMIC PARAMETERS AFTER 1<sup>ST</sup>, 2<sup>ND</sup>, AND 3<sup>RD</sup>  
EXERCISE COMPARED WITH THOSE AT REST

	At Rest	EXERCISE		
		1 <sup>st</sup> Exercise	2 <sup>nd</sup> Exercise	3 <sup>rd</sup> Exercise
Heart Rate (beat/s)	76±10	92±17*	95±17*	100±16*
SBP (mmHg)	106±12	116±14*	117±14*	118±15*
DBP (mmHg)	61±7	59±10*	60±10*	61±10*
CO (L/min)	6.3±1.2	8.5±1.8*	8.7±1.9*	9.2±2.0*

\* significant difference with the results obtained at rest ( $p < 0.01$ ).

The dynamic range of CO estimated from IHAR ( $CO_{\text{IHAR}}$ ) was very similar to that of  $CO_{\text{imp}}$  ( $CO_{\text{IHAR}}$ : 4.02 L/min-14.72 L/min; and  $CO_{\text{imp}}$ : 3.66 L/min-14.48 L/min). As shown in Table II, the standard deviation (SD) of the estimation residue is 0.71 L/min. This value does not vary much with

subject variance, which indicates a stable performance of IHAR based CO estimation. In many previous CO studies, a percentage error (PE) is calculated to indicate the variance of estimation error with respect to reference mean ( $PE = 1.96SD/MEAN_{CO_{ref}}$ ), and a PE less than 30% is regarded to be clinically acceptable [9] [10]. The PE of the results in this study is 16.2 %.

TABLE II

THE SUMMARY OF THE INTRA-SUBJECT CORRELATION COEFFICIENT  $r$  BETWEEN  $CO_{IMP}$  AND IHAR AS WELL AS THE REGRESSION COEFFICIENT AND STANDARD DEVIATION (SD) OF RESIDUE IN THE LEAST SQUARE LINEAR REGRESSION

Subject	$r$	$CO_{IPHA} = \alpha \cdot IHAR + \beta$		SD of Residue (L/min)
		$\alpha$	$\beta$	
S01	0.94*	195.1	3.7	0.83
S02	0.94*	189.6	2.9	0.62
S03	0.78*	265.0	0.9	0.61
S04	0.92*	199.7	2.8	0.64
S05	0.58*	689.0	-3.1	0.87
S06	0.80*	272.0	0.0	0.78
S07	0.91*	347.9	-0.4	0.49
S08	0.79*	256.1	4.8	0.86
S09	0.96*	172.1	2.0	0.38
S10	0.89*	319.7	0.9	0.74
S11	0.83*	396.6	-0.3	0.85
S12	0.96*	282.3	2.4	0.43
S13	0.39	185.9	4.9	0.78
S14	0.78*	345.1	0.2	0.90
S15	0.69*	283.7	4.2	0.83
S16	0.90*	245.8	4.2	0.72
<b>Mean</b>	<b>0.82</b>			<b>0.71</b>

\*  $p < 0.01$ .

The Bland-Altman plot (see Fig. 4) shows the agreement of the estimated CO and the reference CO. The percentage of CO estimations within the 95% confidence interval ([-1.40 L/min -1.40 L/min]) is 95.9%.

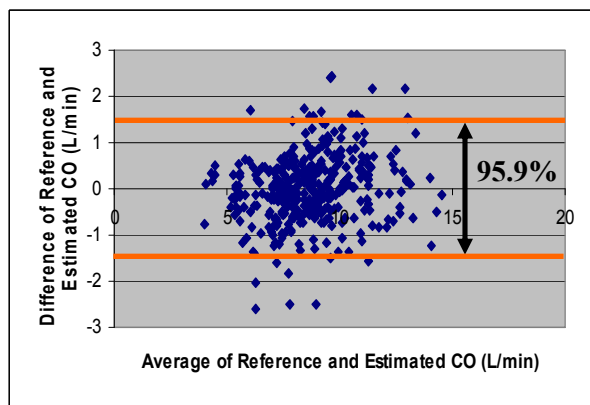

Fig. 4. Bland-Altman plot of cardiac output.

## VI. CONCLUSION

In this study, we have tested the performance of a new CO index, IHAR, in 16 normotensive subjects through a bicycle exercise study. The strong intra-subject correlation suggests that IHAR can successfully trace the CO changes over a wide dynamic range before and after exercise. The small

percentage error (PE = 16.2 %) of our technique is well below the clinically acceptable error of 30%.

A potential limitation of this work is the change of PPG wave as a result of vascular aging or cardiovascular diseases, e.g., the inflection point may be blurred and difficult to find as the arterial stiffness increases. Therefore, further validation on subjects with a bigger age range and cardiovascular patients are needed. Another limitation is the calibration procedure. Since the main purpose of this study is to propose and evaluate a novel CO index, we have not fully investigated the calibration procedure. Only a simple least squares linear regression was utilized. However, individual calibration is an essential procedure for IHAR based CO estimation and will be investigated further in a separate study.

## REFERENCES

- [1] L. Mathews and K. RK Singh, "Cardiac output monitoring," *Annals of Cardiac Anaesthesia*, vol. 11, Jan.-Jun. 2008, pp. 56-68.
- [2] R. Richard, E. Lonsdorfer-Wolf, A. Charloux, et al., "Non-invasive cardiac output evaluation during a maximal progressive exercise test, using a new impedance cardiograph device," *Eur J Appl Physiol.*, vol. 85, Aug. 2001, pp. 202-7.
- [3] H. Lax, A. Feinberg and B. M. Cohen, "Studies of the arterial pulse wave and its modification in the presence of human arteriosclerosis," *J Chronic Dis.*, vol. 3, Jun. 1956, pp. 618-31.
- [4] P. J. Chowieczyk, R. P. Kelly, H. MacCallum, et al., "Photoplethysmographic assessment of pulse wave reflection: blunted response to endothelium-Dependent Beta<sub>2</sub>-Adrenergic vasodilation in type II diabetes mellitus," *J Am Coll Cardiol*, vol. 34, Aug. 1999, pp. 2007-14.
- [5] L. Wang and Y. T. Zhang, "A novel photoplethysmogram index for total peripheral resistance after bicycle exercise," *Proc. of the 5<sup>th</sup> International Conference on Ubiquitous Healthcare*, Pusan, Korea, Oct. 2008, pp. 175-6.
- [6] D. McCombie, A. Reisner and H. Asada, "Identification of vascular dynamics and estimation of the cardiac output waveform from wearable PPG sensors," *Proc. of the 27<sup>th</sup> IEEE International Engineering in Medicine and Biology Conference, EMBC 2005*, Shanghai, China, pp. 3490-3.
- [7] Y. S. Yan and Y. T. Zhang, "Noninvasive estimation of blood pressure using photoplethysmographic signals in the period domain," *Proc. of the 27<sup>th</sup> IEEE International Engineering in Medicine and Biology Conference, EMBC 2005*, Shanghai, China, pp. 3583-4.
- [8] A. Charloux, E. Lonsdorfer-Wolf, R. Richard, et al., "A new impedance cardiograph device for the non-invasive evaluation of cardiac output at rest and during exercise: comparison with the "direct" Fick method," *Eur J Appl Physiol.*, vol. 82, Jul. 2000, pp. 313-20.
- [9] M. Biais, K. Nouette-Gaulain, V. Cottenceau, et al., "Cardiac output measurement in patients undergoing liver transplantation: pulmonary artery catheter versus uncalibrated arterial pressure waveform analysis," *Anesth Analg.*, vol. 106, May 2008, pp. 1480-6.
- [10] L. A. Critchley and J. A. Critchely, "A meta-analysis of studies using bias and precision statistics to compare cardiac output measurement techniques," *J Clin Monit Comput.*, vol. 15, Feb. 1999, pp. 85-91.